

SCHEDA TECNICA - PUFFER PSM -PSR - PSF

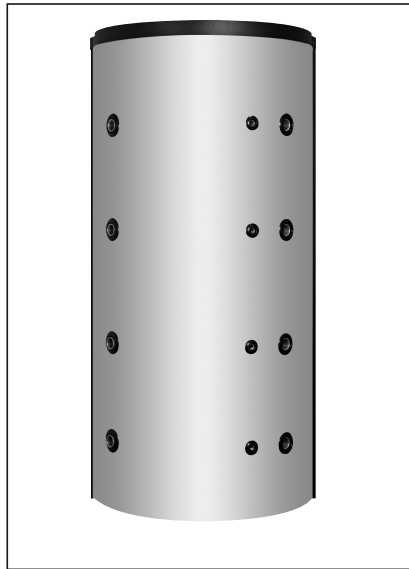

**PSR/PSRR buffer tank
with heating coil**
PSR 500 - 5000l
PSRR 500 - 3000l



PSM buffer tank with 6/4" coupling sleeves
500 - 5000l



**PSF buffer tank
Flange D 240**
500 - 5000l

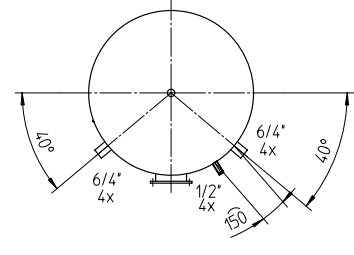
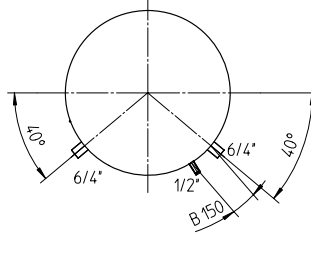
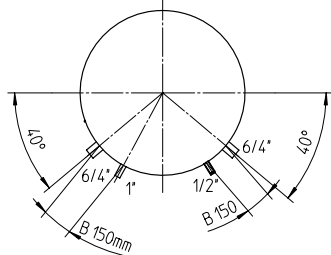
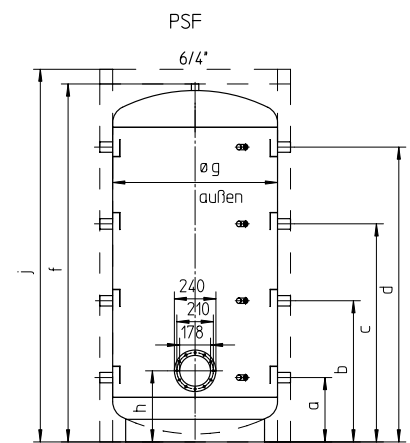
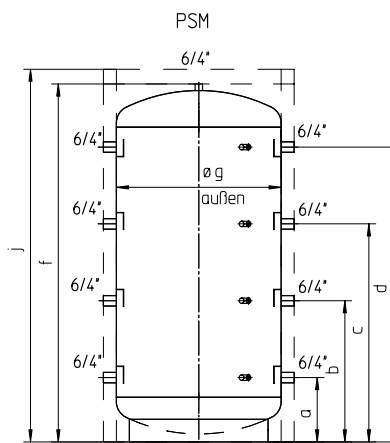
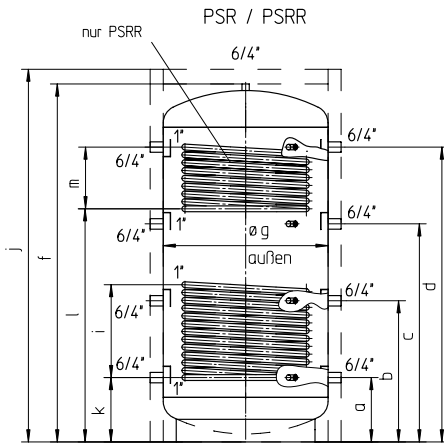

Volume [l]	Dimensioni in mm											Altezza di ribaltamento mm	Superficie tubo m ²		Capacità tubo lt		
	a	b	c	d	f	Øg	h	i	j	k	l		m	alto	basso	alto	basso
500	220	620	1010	1390	1640	650	340	495	1725	220	-	-	1670	-	1,8	-	11
800	260	630	1030	1430	1700	790	390	585	1785	260	1070	360	1750	1,8	2,4	11	15
825	260	685	1140	1595	1857	790	-	-	1940	-	-	-	1900	-	-	-	-
1000	310	745	1250	1710	2050	790	390	720	2135	310	1160	540	2090	2,4	3,0	15	19
1500	380	825	1350	1760	2150	1000	415	800	2235	375	1260	500	2270	2,4	3,6	15	22
2000	320	900	1490	2020	2380	1100	423	800	2465	320	1420	540	2460	2,8	4,2	18	26
3000	375	985	1600	2205	2596	1250	460	720	2681	375	1665	540	2650	3,0	4,5	19	29
4000	405	1022	1639	2255	2669	1400	490	720	2754	405	1715	540	2740	3,6	5,0	22	32
5000	455	1065	1680	2285	2770	1600	540	720	2855	455	1745	540	2893	4,2	6,0	26	39